



IMM biogas reformer / CHP system

Hydrogen supply and energy generation for stationary applications

Stationary fuel cell applications require compact and sustainable hydrogen supply considering also the still limited availability of compressed or cryogenic hydrogen. For many applications, biogas is a sustainable alternative to natural gas. Biogas is produced in more than 9,000 biogas plants in Germany nowadays, which will inject into the natural gas grid increasingly in future.

The conversion of biogas to hydrogen (reforming) requires an operating temperature of the reforming process in the range of 750 °C. Fraunhofer IMM biogas reformer technology has been specifically developed for this temperature level.

The hydrogen content of reformed biogas (reformate) is then increased through downstream catalytic conversion process, the water-gas shift reaction. Subsequently the removal of traces of residual carbon monoxide is achieved through the preferential oxidation reaction as shown in the graphic on the next page.

The reformate is then fed to a fuel cell (possible are high and low temperature PEM fuel cells) which produce electric power.

Catalyst coated reformer

IMM has developed a highly compact biogas reformer, which has several advantages compared to conventional technology, which originate from our unique catalyst and reactor technology:

- Robust catalyst, no pre-treatment necessary, no performance drop after longer shut-down.
- Higher activity compared to conventional technology (originating from large scale industrial processes) allows minimum catalyst demand (and cost).
- Catalyst coatings similar to automotive exhaust cleaning increase the utilization and reduces catalyst demand further.
- Stable reactor operation at partial load allows system modulation.
- This along with the intrinsically stable efficiency of fuel cells at partial load allows higher system efficiency.
- Plate heat exchanger technology allows optimum heat integration and higher system efficiency compared to conventional technology (fixed bed reactors).
- Reactor fabrication similar to automotive high pressure heat exchangers or fuel cell metallic bipolar plates.
- Cheap fabrication steps: Embossing, screen printing and laser welding allow cost reduction for product ramp-up.

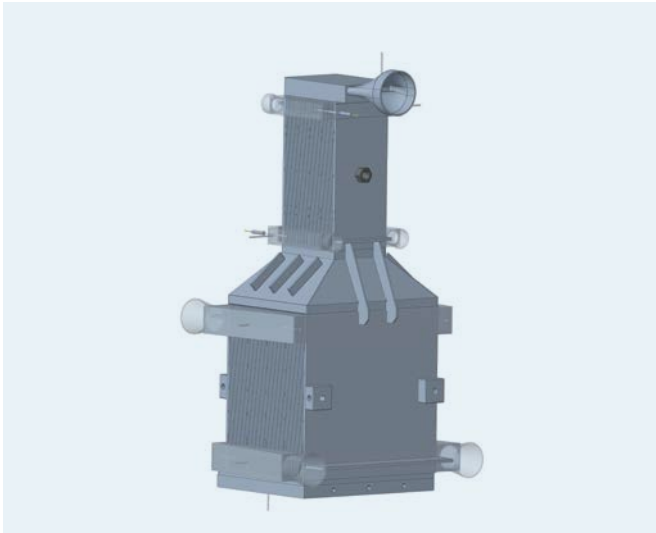

IMM compact biogas steam reformer reactor technology – tailor-made for the reaction

Benefit from more than 20 years experience in development of reformers for a large variety of fuels (also methanol, ethanol, diesel and many others).

Conventional biogas steam reforming reactors are fixed bed reactors, a technology which had been developed for large scale chemical processes. They have a number of draw-backs:

- They suffer from catalyst attrition especially when vibrations occur (transportation of containerized plants).
- The catalyst is not fully utilized and consequently even more catalyst is required compared to coated catalyst.
- The heat management is difficult, heat has to be introduced to drive the steam reforming reaction through excessive firing of additional biogas.
- Substantial heat is contained in the fuel cell off-gas which can also not be utilized efficiently.

All these issues are addressed by IMM compact biogas reformer technology. The application of catalyst coatings in a plate heat exchanger allows optimum catalyst utilization and heat management through integrated fuel cell off-gas combustion.

The robustness of this technology has been proven in practical applications under conditions of start-up, stationary operation and load changes.

Benefit from more than 20 years experience in fuel processor development for stationary, mobile (aviation, maritime, ground transport) and portable applications. Apart from the reformer, the fuel cell hydrogen supply requires devices for evaporation, water-gas shift and in case low temperature PEM fuel cell technology is connected, a reactor for CO removal and other balance-of-plant. The whole assembly is named fuel processor.

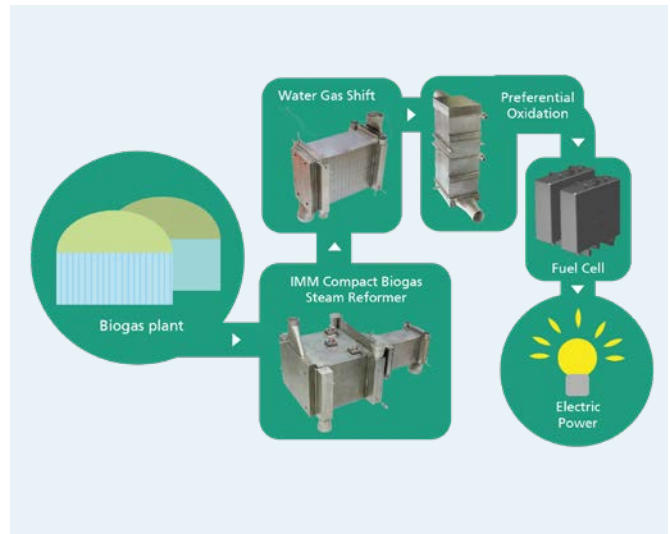

IMM has developed compact and highly integrated high-performance components for that. The fuel processor design needs to be optimized for your specific application:

- the fuel cell type
- the power range
- the specific environment
- the specific market requirements (achievable price and sales numbers) because fabrication techniques need to be chosen accordingly

Talk to our experts to get the optimum solution for your system!

Contact

Dr. Gunther Kolb
Head of Division Energy
Phone +49 6131 990-341
gunther.kolb@
imm.fraunhofer.de

Fraunhofer Institute for
Microengineering and
Microsystems IMM
Carl-Zeiss-Strasse 18-20
55129 Mainz | Germany
www.imm.fraunhofer.de

All flyers of the division Chemistry
<https://s.fhg.de/flyers-energy>



© Fraunhofer IMM, Mainz 2024